

Specifications

Rating	0.2A 48VDC
Electrical Life:	300,000 cycles min.
Operating Temp:	-10°C ~ +60°C
Contact Resistance:	50mΩ max. initial
Insulation Resistance:	100 MΩ min.
Dielectric Strength:	500VAC for 60 +/- 5 sec
Contacts:	Silver plated
Circuit:	2P2T 1P2T
Change-over-time:	Shorting Non-shorting
Operating Force:	50 +/- 15gf



Ordering qty: 500pcs

PCB Layout

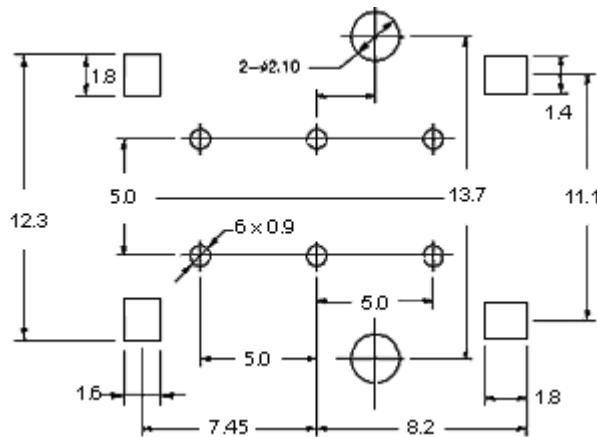

Dimensions/Drawings

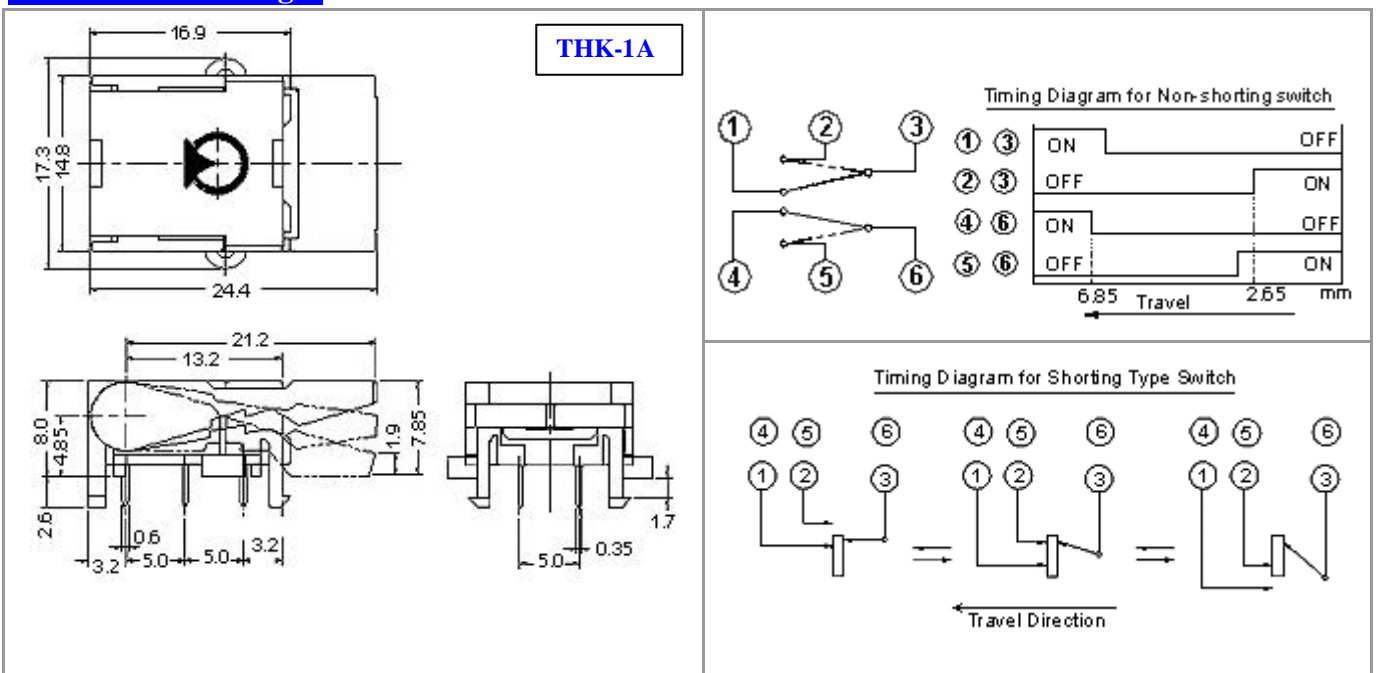

Dimensions/Drawings

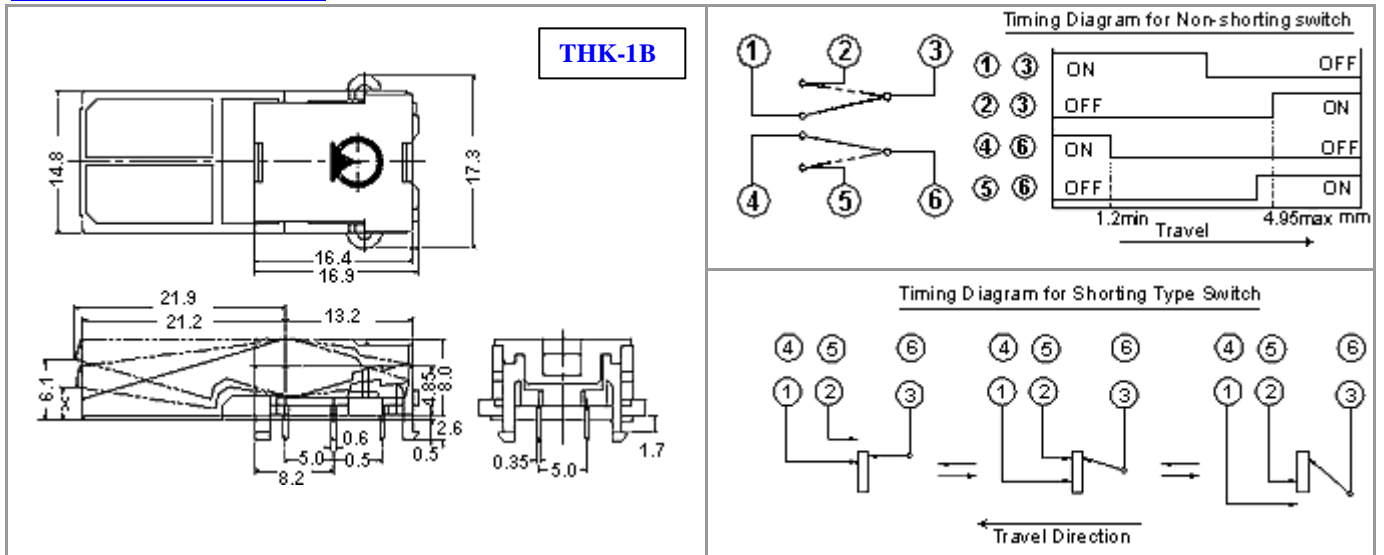

Standard Models

Part-number	Timing	Circuit	Flammability
THK-1AN-0001	Non-shorting	2P2T	UL94 HB
THK-1AS-0004	Shorting	2P2T	UL94 HB
THK-1BN-0002	Non-shorting	2P2T	UL94 HB
THK-1BS-0023	Shorting	2P2T	UL94 HB
THK-1CN-0003	Non-shorting	2P2T	UL94 HB
THK-1CS-0009	Shorting	2P2T	UL94 HB